

B5.9

195LPG



S P E C I F I C A T I O N S

P E R F O R M A N C E

Curves shown represent gross engine performance capabilities obtained and corrected in accordance with Cummins Standards. Standard Conditions are: 29.36 in.Hg (99.14 kPa) barometric Pressure [500 ft. altitude, 77°F (25°C) inlet Air Temperature], Liquid Petroleum Gas at 104°F (39°C) inlet temperature and meeting Cummins specified recommendations (HD-5). The engine may be operated in a transient mode up to 8500 ft. (2600 m) altitude and 100° F (38° C). However, when ambient and/or installed conditions vary from the Standard Conditions, performance characteristics can be expected to vary according to the guidelines in Cummins Standard. At time of engine shipment, performance will be within ± 5% at Rated Power & Rated Torque.

The BSFC curve shown is at full load conditions. This is not a true indicator of fuel tank mileage due to the fact that the engine spends only a portion of time operating on the full load curve. A significant amount of time is spent at various part load conditions. Therefore, full load BSFC curves should not be used as an indicator of fuel tank mileage.

Cummins does not recommend continuous application of this engine at altitudes greater than 8,500 feet. Higher altitude operation may result in performance degradation. No engine damage or decrease in durability should be expected. For cold weather operation, a minimum of 35 psig to engine is required of vehicle fuel system.

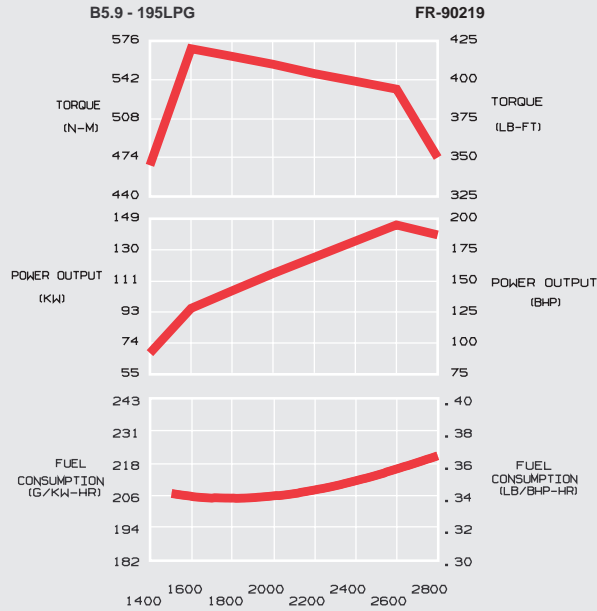

S P E C I F I C A T I O N S

B5.9-195LPG

Maximum Horsepower	195 bhp	(146 kW)
Rated Speed	2600 rpm	
Peak Torque	420 lb.-ft.	(569 N•m)
Governed Speed	2800 rpm	
Number Cylinders	6	
Engine Displacement	359 cu. in.	(5.9 L)
Bore & Stroke	4.02x4.72 in.	(102x120 mm)
Compression Ratio	9:1	
Operating Cycles	4	
Oil System Capacity	4.0 U.S. gal.	(15 L)
Coolant Capacity	10.5 U.S. qts.	(9.9 L)
Net Weight with Std Accessories, Dry	910 lbs.	(413 kg)
Altitude Capability	8500 ft.	(2600 m)
Installation Diagram Number	3170279	



DESIGN FEATURES

Air Intake System: Charge air cooling is utilized to reduce emission levels by lowering intake manifold temperatures.

Belt Drive System: Self-tensioning polyvee belt accessory drive system eliminates belt maintenance.

Catalyst: Required for meeting CARB/EPA heavy-duty emissions standards and for lowest emissions levels (THC, HCHO, CO and PM).

Complete Rebuildability: The cylinder block has multiple rebore capability. Service cylinder sleeves and valve guides are also available if needed.

Connecting Rods: Drop forged construction maximizes structural strength, and an angle split cap-to-rod interface and capscrew attachment makes servicing easier.

Control/Ignition System: Cummins CM420 electronic engine control module manages the Cummins High Energy Ignition System and other critical engine parameters.

Air/Fuel Regulation: Cummins closed loop electronic control system.

Turbocharger: A new Holset water-cooled turbocharger with an electronically controlled wastegate provides improved response and performance.

Crankshaft: Induction-hardened forged steel crankshaft provides maximum strength and multiple regrind capability for long-term cost savings. Crankshaft supported by seven main bearings for optimum durability.

Cylinder Head: Short length crossflow cylinder head for maximum structural strength of the block and head assembly, resulting in long trouble-free life.

Parts Simplicity: Enables engines to be serviced and repaired with ordinary hand tools. Up to 40% fewer parts than competitive engines.

Pistons: For extended piston and ring life, a Ni-Resist ring insert is cast into the aluminum alloy piston.

FUEL/OIL REQUIREMENTS

Fuel: LPG Fuels must meet Cummins specified recommendations (HD-5). Engine performance will vary with heating values of customer's respective fuels. Engine durability and performance may be reduced when operated with poor quality and/or contaminated fuel. For cold weather operation, a minimum of 35 psig to engine is required of vehicle fuel system.

Oil: Cummins Liquid Petroleum Gas Engines should be operated only on lubricating oils which meet Cummins Natural Gas Lubricating Oil Requirements as specified in engine Operation & Maintenance Manuals. Engine durability may be adversely affected when lower grade/types of lubricating oils are utilized.

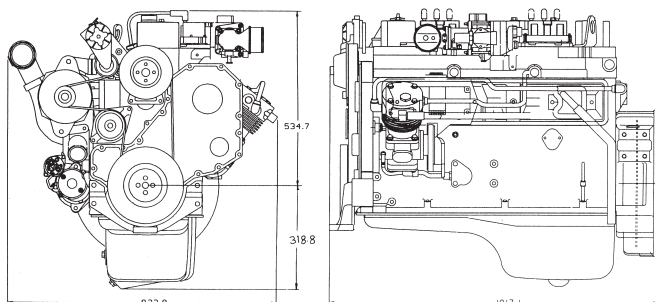

APPLICATION AND GEARING CONSIDERATIONS

B5.9-195LPG

The B5.9-195LPG is ideal for 20,000 - 32,000 lb. short-haul applications such as local pickup and delivery vehicles and buses and on/off highway applications such as refuse trucks and dump trucks. Its broad power band provides excellent performance when matched to various medium-duty manual and automatic transmissions.

The following chart is a guideline to aid in transmission selection for these applications:

Gross Weight	Vehicle Configuration	Recommended Transmission Type
On - Highway Applications		
26,000 lbs.	4x2 Straight Truck	5, 6 or 7 speed
32,000 lbs.	4x2 Straight Truck	5, 6 or 7 speed
On/Off - Highway Applications		
26,000 lbs.	4x2 Straight Truck	9 speed
32,000 lbs.	4x2 Straight Truck	9 speed

The chart below illustrates the road speeds at governed engine speed that result from using various rear axle ratios in conjunction with 501 rev/mile tires and a direct drive transmission

2800 rpm Governed Engine Speed

Axle Ratio	MPH @ 2800 rpm
5.13	65
5.78	58

For more specific automatic and manual transmission gearing recommendations, consult your truck dealer or Cummins Distributor.

AUTOMATIC TRANSMISSION INFORMATION

The B5.9-195LPG will deliver the optimum balance of performance and fuel economy if matched correctly with an automatic transmission. Select the proper rear axle ratio for the vehicle's tire size and desired top speed.

For transmission recommendations specific to your application, contact your local transmission dealer or Cummins distributor. Typical torque converter matches:

B5.9-195LPG			
	AT-545/	MT-643/	MD-3066
	AT-542	MT-653	MD-3560
B5.9-195LPG	TC-290	TC-360	TC-411



Cummins Engine Company, Inc.
Box 3005
Columbus, IN 47202-3005
U.S.A.

Bulletin 3885387
Printed in U.S.A. Rev. 6/98

© 1998 Cummins Engine Company, Inc.

Cummins has always been a pioneer in product improvement. Thus specifications may change without notice. Illustrations may include optional equipment.